

The Effect of Continuous Cooling Heat Treatment on Interface Properties of SK3/Copper Compound Casting

C.B. Lin, and J.-S. Ho

(Submitted 27 April 1999; in revised form 27 August 1999)

The bonding of an SK3 steel insert to copper during cast welding and heat treatment was studied. The interface shear strength was made with a push-out test. After cast welding, a cast welding layer formed between SK3 steel and copper. After a continuous cooling heat treatment, there was a cast welding layer near the SK3 steel matrix, an irregular layer near the copper matrix, and a middle layer between them. X-ray diffraction analysis was used to determine that the interface layer consisted of carbon and CuFeO_2 . Through electron probe x-ray microanalysis (EPMA), it was shown that mainly iron atoms and carbons diffused into the copper matrix. The interface shear strengths of the compound casting while with water quenched, oil quenched, air cooled, and furnace cooled, were 23.42, 18.74, 12.29, 13.43, and 8.33 MPa, all of heat treatment fractures in the cast welding layer near the SK3 steel matrix.

Keywords compound casting, continuous cooling, copper/steel cladding

1. Introduction

Adding a strengthening phase to a copper matrix to form copper matrix composites was often done to improve mechanical properties when copper or copper alloy was used as the electrical contact material. Schilling and Grant^[1] used the internal oxidation of a copper-aluminum alloy to produce alumina in the copper matrix. Warrior and Rohatgi^[2] showed that mechanical properties could be improved by adding TiO_2 particulate to copper. Peterson *et al.*^[3] proved that conductivity, heat conductivity, and mechanical properties of copper alloy could not be changed by raising the temperature if 1 wt.% ThO_2 was well distributed in the copper alloy. After being heated to a proper temperature, through *in situ* processing of metal, two or more metal elements were remelted, and with the exothermic reaction, TiB_2 particulates of 50-nm distribution in the copper matrix were formed; the conductivity of the copper matrix containing 5 vol.% TiB_2 particulate could reach 76% of the international annealed copper standard (IACS). At 20 °C, resistance was 1.724×10^{-6} ohm/cm², but when the working temperature was over 500 °C, 80% of IACS was needed to obtain a fine conductivity.^[4] Chrysanthou and Erbaccio^[5] verified that during *in situ* processing of copper matrix composites, the products of Cu/ TiB_2 composites had a high conductivity and strength.

The quality of wettability between two types of metals or a metal and nonmetal is significant for determining the bonding.^[6] In addition, characteristics of materials and velocity, temperature, and time of diffusion should be considered as the effects of bonding.^[7] Durrant *et al.*^[8] pointed out that when mild steel was used to strengthen an aluminum alloy, some grease and other impurities on the surface of the mild steel were removed by using

acetone. The mild steel was treated with hot dipping and vacuum plasma spraying to separately form Al-10%Fe and titanium reacted layers, which can increase the steel's wettability with an aluminum alloy.

Shieu *et al.*^[9] pointed out that in the interface reaction of NiO and platinum, the forming of a solid solution interlayer in the interface can promote the shear stress of the composites. Choi *et al.*^[10] found that during the reaction of titanium and SiC, there was a thermodynamic driving force to make titanium and SiC produce reactants. In the research of the relation between fracture toughness and interface reaction of titanium and Al_2O_3 , Lu *et al.*^[11] pointed out that the decline of fracture toughness was due to the forming of some hard and brittle intermetallic compounds and cavities in the interface. According to the report of interface cracks made by Evans *et al.*,^[12] the appearance of cracks was mainly affected by two constants: energy release rate and mode mixity angle, ϕ ($\phi = 0$ means open cracks; $\phi = \pi/2$ means shear cracks).

In the research of using heat treatment to improve mechanical properties, Klomp^[13] found that heat treatment with different conditions produced different bonding strengths in the interface of composites. By using austempering heat treatment, Moore *et al.*^[14] changed the distribution and the size of ferrite iron grains and produced carbon steel to obtain the ductility of austenite steel with high strength and high toughness. Under melting point, Qian *et al.*^[15] added steel wire to molten white cast iron, finding that some features of austenite steel or phase transformation were left in the interface of steel and iron.

Pushing out and pulling out are often used to test interface strength.^[16-18] Observing the microstructure of interface through scanning electron microscopy (SEM) and transmission electron microscopy, testing interface strength by pushing out, and then analyzing interface composition through energy dispersive spectrometry (EDS), electron energy-loss spectroscopy (EELS), and x-ray photoelectron spectroscopy (XPS) are the interface analytical steps explained in the report by Lewis and Murthy.^[19]

In this paper, after cast welding pure copper and SK3 hyper-eutectoid steel, four continuous cooling heat treatments, including water quenching, oil quenching, air cooling, and furnace

C.B. Lin and J.-S. Ho, Department of Mechanical Engineering, Tamkang University, Tamsui Taipei, Republic of China.

cooling, were used on the compound casting. Heat treatment was used to promote the hardness of the SK3 steel matrix and shear strength of the interface between SK3 steel and pure copper. To distinguish the change of the composition and the microstructure of SK3 steel and interface before and after heat treatment conditions, the microstructure of the compound casting was observed by optical microscopy (OM) and SEM, the interface phase by x-ray diffraction analysis, and the composition by EDS and electron probe x-ray microanalysis (EPMA). Moreover, pushing-out analysis was used to test interface shear strength.

2. Experimental Procedure

2.1 Materials Production

Copper of 99.98% as the matrix and SK3 steel with a diameter of 10 mm and a length of 240 mm as the reinforcement (the chemical composition was ~ 1.00 ~ 1.10% C, less than 0.35% Si, less than 0.50% Mn, less than 0.030% P, and less than 0.030% S) were cast welded together. For the process of cast welding, carbimet paper of 1200 grid was used to polish the surface of SK3 steel; oxides and grease on the surface of the steel rod were removed by alkaline washing solution (composed of 16wt% NaCO₃ with H₂O, the balance alkaline), washing temperature 90 ± 5 °C, and then water was used to clean the rod. The water left on the surface of the steel rod was quickly eliminated by drying with compressed argon gas; at last, a compound casting was formed by cast welding treated SK3 steel to molten copper at 1150 °C. For the entire cast welding procedure, argon gas was used to prevent surface oxidation of SK3 steel. Figure 1 shows the apparatus of cast welding and the compound casting.

2.2 Heat Treatment

To determine the effect of different heat treatment conditions on the interface, the compound casting was cut into specimens with a 20-mm diameter and a 15-mm thickness, preheated to 760 ± 3 °C, and then isothermally heated for 2 h. Subsequently, four continuous cooling heat treatments, including water quenching (cooling by stirring in icy water for 60 s at 10 ± 2 °C), oil quenching (cooling by stirring in 27 °C, ± 3 °C, oil bath for 90 s in the isothermal condition), air cooling to 27 ± 3 °C, and furnace cooling to 27 ± 3 °C, were used, respectively, to cool the specimens. In addition, Table 1 lists the properties of the quench oil.

2.3 Microstructure Observation

The cut cross section of heat-treated compound casting was ground by carbimet paper of 100 to 1200 grid, polished by a suspension liquid of 0.3-µm Al₂O₃ particulate, and etched by an etching solution (95% ethanol + 5% nitric acid) for 3 s. Then, through OPTIPHOT-100 Nikon OM (Nikon Corp., Tokyo) and JEOL-JSM 840A SEM (Japan Electron Optics Ltd., Tokyo), the microstructure of SK3 steel and the interface were observed. Moreover, the relative proportion of iron to copper in the interface was analyzed through the line scan of JEOL (JEOL USA, Inc., MA) JXA-8800M EPMA.

For x-ray diffraction analysis, each interface formed after cast welding and heat treating was taken out to be ground into pow-

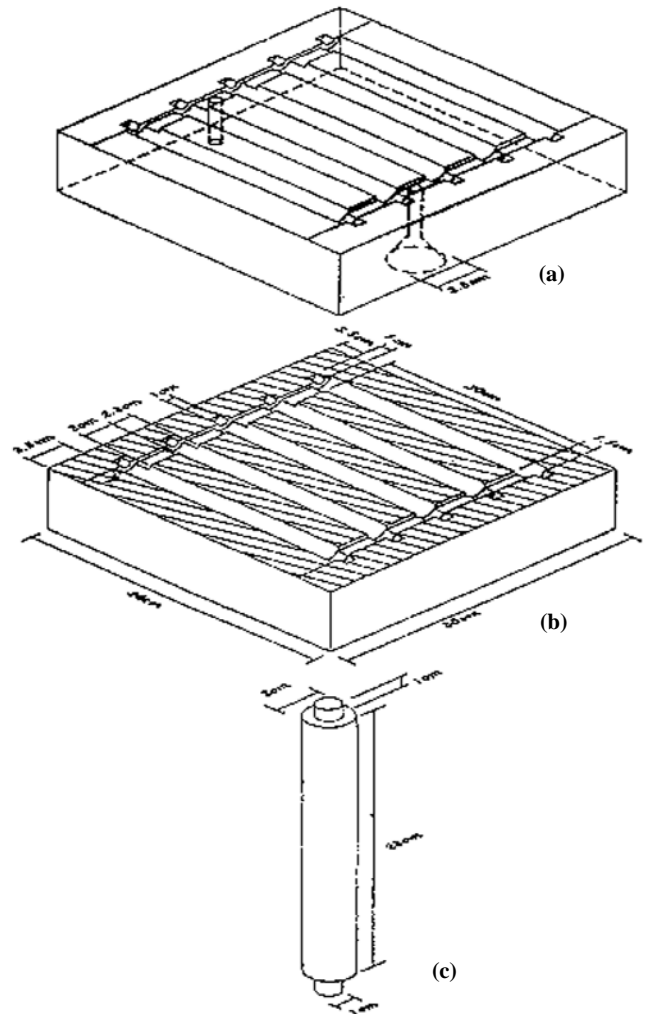

Fig. 1 (a) to (c) Apparatus for cast welding and compound casting

Table 1 Properties of the quench oil

Properties	Value
Gravity, D287 15.6 API	30.5
Viscosity kin: cSt, 40°C (100°C)	28.0 (5.10)
Viscosity index, D2270	106
Flash point, COC, °C (°F)	228 (442)
Fire point, COC, °C (°F)	-7.7 (18)
Color, D1500	2.5

der. Then the analysis of interface was made using a MAC Science MXP-3TXT-A104 x-ray diffraction analyzer (Shimadzu Co., Kyoto) with a 3 kW x-ray generator, copper target, 1.54056 Å wavelength, 40 kV voltage, and 30 mA current. The speed of 4°/min was used for scanning from 20 to 80°.

2.4 Push-Out Test

The testing rig for the push-out tests consisted of an SKD11 (HRC62) tool steel lower plate with a 10.2-mm-diameter hole. A

250-mm-thick disk from the heat-treated compound casting was placed on the plate, and a 9.8-mm-diameter SKD11 (HRC62) tool steel punch was used to push out the SK3 steel insert. The push-out test was performed using an HT-9102. Instron (Hung Ta Instrument Co., Ltd., Taiwan) testing machine. The SK3 steel of the compound casting was pushed out at the crosshead speed of 5 mm/min. According to Durrant's theory,^[8] the shear stress of the interface was equal to $L/[\pi D(t-d)]$ (L is the area of inserting reinforcement, D is the diameter of inserting reinforcement, t is the thickness of the specimen, and d is the push-out distortion displacement of reinforcement, not including elastic distortion). Based upon this theory, interface strength was obtained, and the average was determined from three selected data.

2.5 Fracture Morphology Observation

Using OPTIPHOT-100 Nikon OM, the fracture morphology of the pushed-out specimen was observed. Additionally, the fracture morphology of the interface around the fracture area, which could not be observed through OM, was observed after the specimen was polished and etched prior to the push-out testing.

3. Results and Discussion

3.1 Microstructure Observations

Figure 2(a) shows the microstructure of SK3 steel and copper after cast welding. It was found that an interface, called the cast "welding layer," was formed between SK3 steel and copper because the molten copper of 1150 °C was cast welded directly with SK3 steel to form the reacting layer while it was poured into the preheated sand mold.

After SK3 steel and copper were cast welded together and a continuous cooling heat treatment was used on the compound casting, its interface, shown in Fig. 2(b) to (e), was divided into three main sections. The section closest to the SK3 steel was the cast welding layer (I), the layer closest to the copper was an irregular layer (III), and the last layer in between was the middle layer (II).

Figure 3 shows the microstructure of SK3 steel after continuous cooling heat treating. Figure 3(a) shows the microstructure of the water quench. It was found that the microstructure of SK3 steel was martensitic phase. The microstructure of the oil-quenched specimen was mixed with fine pearlite and martensite phase, shown in Fig. 3(b). The microstructure of the air-cooled specimen with the medium pearlite is shown in Fig. 3(c). The microstructure of the furnace-cooled specimen was mixed with coarse pearlite and spheroidal cementite, as shown in Fig. 3(d). It was found that after continuous cooling heat treatment, the microstructure of the nearby cast welding layer contained a ferrite region, as shown in Fig. 3(e). The ferrite region was formed when the heat of molten copper (1150 °C) was transferred to the surface of SK3 steel, raising the temperature of the surface to cause decarbonization.

3.2 X-Ray Diffraction and EPMA

A cast welding layer produced from the cast welding of SK3 steel and copper was taken out and ground into powder for x-ray diffraction analysis and determination of chemical compounds

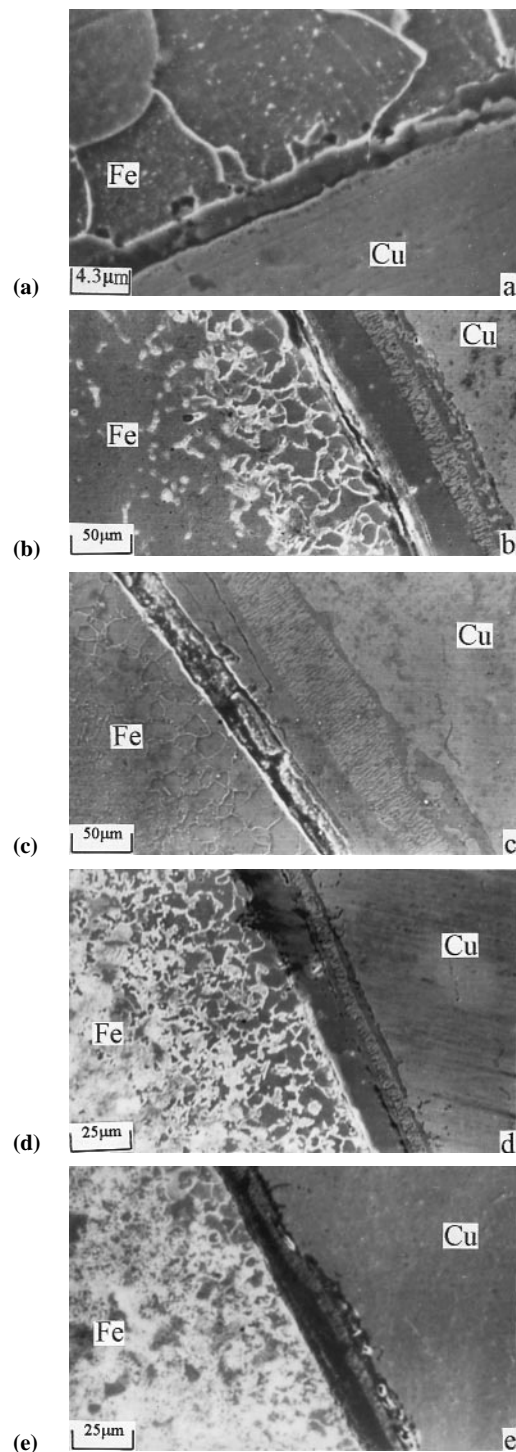

Fig. 2 SEM photograph of SK3 steel/copper compound casting. (a) Before heat treatment. (b) Water quenching. (c) Oil quenching. (d) Air cooling. (e) Furnace cooling

(such as CuFeO_2 and C), which have the peak values shown in Fig. 4. The analysis of x-ray diffraction after continuous cooling heat treatment was also completed. Those results were the same as Fig. 4. The interdiffusion of copper atoms and iron atoms

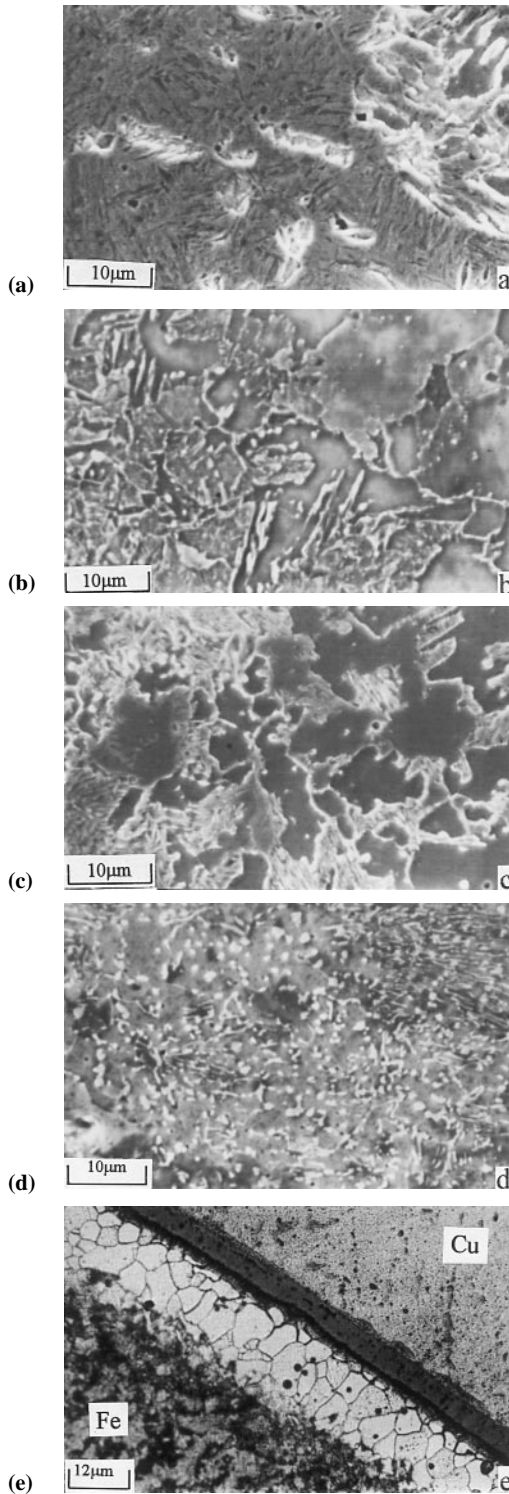

Fig. 3 SEM photograph of SK3 steel matrix. (a) Water quenching. (b) Oil quenching. (c) Air cooling. (d) Furnace cooling. (e) Optical microscope of a carbon-free region near the cast welding layer

caused CuFeO_2 to form, and the decarbonization of the SK3 steel surface caused carbon in the interface. The EPMA qualitative analysis, the line profile, and the corresponding SEM photo-

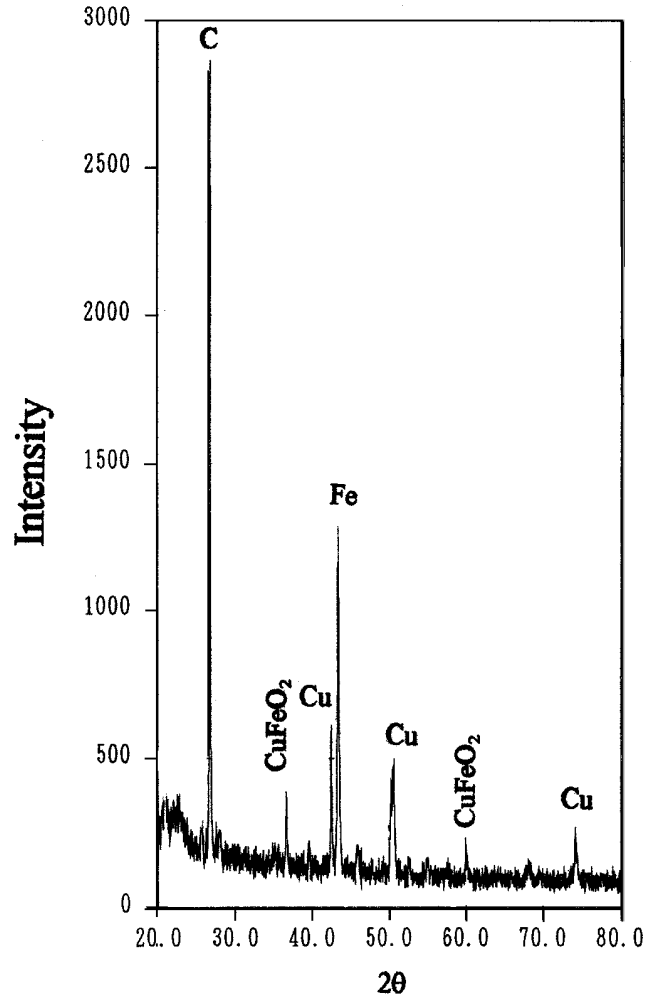
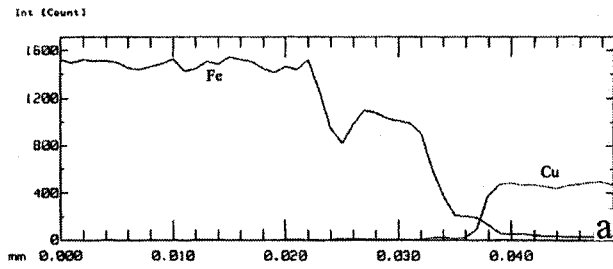

Fig. 4 X-ray analysis of SK3 steel/copper compound casting

graph iron map and copper map of cast-welded SK3 steel and copper are shown in Fig. 5(a) to (d). According to these results, the iron content is more than that of copper in the cast welding layer. After annealing for 2 h at 760 °C, and using the oil cooling heat treatment shown in Fig. 6(a) to (d), the EPMA after water quench, air cooling, and furnace cooling was completed. The results were the same as Fig. 6(a) to (d). These results show that iron atoms tend to mostly diffuse to copper matrix. The reason is that the cast welding layer has a high concentration of carbon and can thus effectively prevent copper atom diffusion into the SK3 steel matrix.

The contents of iron and copper of cast-welded SK3 steel and copper were approximately 72 and 0.64%, respectively. The average contents of iron and copper in the continuous cooling heat-treated cast welding layer were approximately 56 and 0.56%, respectively. The contents of iron and copper in the middle layer were approximately 72 and 0.40%, respectively. The contents of iron and copper in the irregular layer were approximately 70 and 1.50%, respectively. Through EPMA, it was found that in the entire process of cast welding and continuous cooling heat treatment, most diffusion resulted from iron diffusing into the copper matrix to further produce copper-iron compounds;



(a)

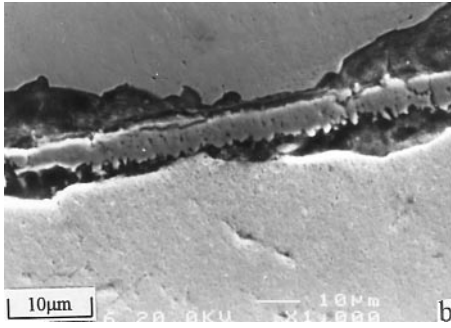

(b)

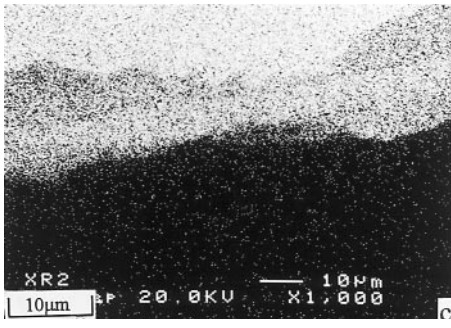

(c)

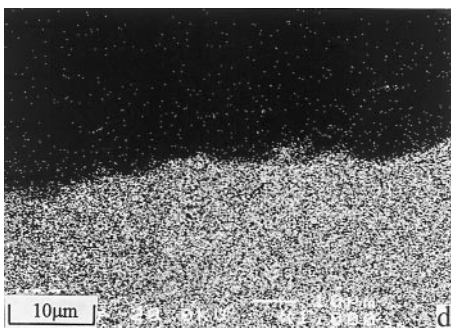

(d)

Fig. 5 EPMA of SK3 steel/copper compound casting. (a) Line profile. (b) SEM photograph. (c) Iron map. (d) Copper map

however, there was only a small amount of copper diffusion to the steel matrix. The cast welding layer had the highest content of carbon. The middle layer had a similar content of carbon with an irregular layer; that is, the cast welding layer in solid solution had more carbon decarburizing from the SK3 steel matrix.

3.3 Mechanism Formed in Interface

The mechanism of three sections formed in the interface after molten copper of 1150 °C was poured. The surface of the

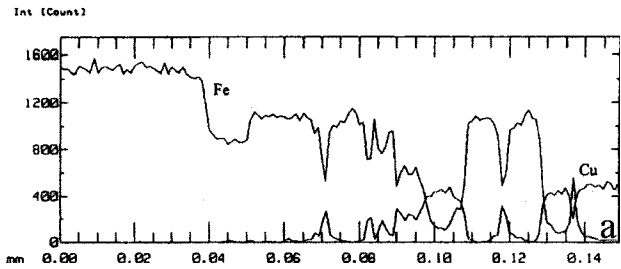

(a)

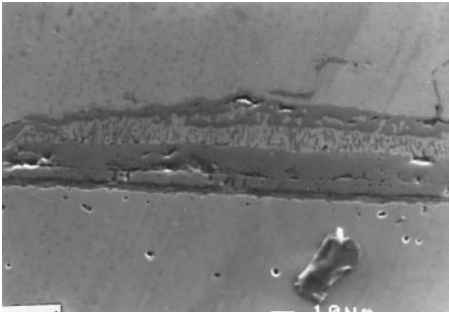

(b)

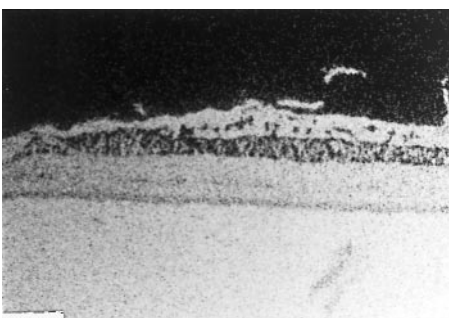

(c)

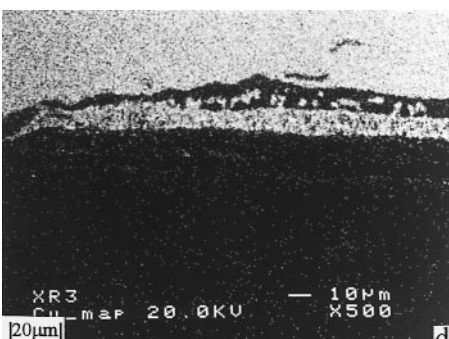

(d)

Fig. 6 EPMA analysis of SK3/copper compound casting around marquenching. (a) Line profile. (b) SEM photograph. (c) Iron map. (d) Copper map

SK3 steel rod at normal temperature was melted to form a cast welding layer; meanwhile, the heat of molten copper was transmitted to the rod surface of SK3 steel, raising the temperature of the surface to cause decarburization. The cast welding layer thereby had a high concentration of carbon and fewer copper atoms to interdiffuse with iron atoms. The compound casting was put in an isothermal furnace for 2 h at 760 °C to obtain diffusion

within. At this temperature, the diffusion coefficient of iron diffusing to the copper matrix was quicker than that of copper to the iron matrix; therefore, iron atoms passed over the cast welding layer from the matrix to the copper matrix to form the middle layer. The width of such a reacted layer developed with time. While iron atoms were diffusing to the copper matrix, carbon atoms in the cast welding layer also diffused to the middle layer in succession, with solid solution in the interstitial of the iron unit cell, and the higher concentration of carbon effectively prevented copper atoms from passing over the cast welding layer. Diffusion continued, and iron atoms in the middle layer formed $(\text{Fe-C})_x$, with supersaturated carbon to effectively prevent copper atoms with a slower diffusion rate from entering the middle layer. Diffusion continued, through the routes formed among the $(\text{Fe-C})_x$ particulate in the middle layer, and iron atoms diffused to the copper matrix. Thus, an irregular layer was formed. Connections and diffusing routes were formed while iron atoms diffused in all directions in the copper matrix. Then a secondary middle layer also formed in the irregular layer, as shown in Fig. 7.

3.4 Push-Out Analysis of Interface

Before heat treating, the average interface shear stress of a cast welding layer formed by cast welding SK3 steel and copper was 23.42 MPa. After heat treating, the respective average interface shear stresses of a water-quenched, oil-quenched, air-cooled, and furnace-cooled cast welding layer were 18.74, 12.29, 13.43, and 8.33 MPa, respectively. According to Durrant *et al.*,^[8] the shear stress at the interface was $\tau = -\mu p$, where μ is the coefficient of friction and p is the normal stress acting on the insert surface. The magnitude of p was determined by residual elastic stress in the matrix. Figure 3(e) shows that the μ value is equal for all heat treatment conditions because a nearby cast welding layer of SK3 steel matrix for all heat treatment conditions contains a ferrite region; thus, the interface shear strength was only determined by residual elastic stress. Due to the net change in temperature as the cast welding and after heat treatment, the former (1123 °C) was bigger than those of the latter (water quenching was 727 °C, others were 737 °C), so the cast welding had the largest residual elastic stress. With the increase of diffusing time during the process of furnace cooling, the residual elastic stress was released and shear stress was reduced. Figure 8 shows that the fracturing region before heat treating and around heat treating were all in the cast welding layer near the SK3 steel matrix. This was because the region had both high carbon and stress concentrations.

Based on the previous results and discussion, it can be concluded that the SK3 steel/copper compound casting through water quenching heat treatment can simultaneously increase the hardness of SK3 steel and the shear strength of the interface.

4. Conclusions

The following conclusions can be drawn.

- After heat treating, reacted layers formed in the interface. The layer near the SK3 steel matrix was the cast welding

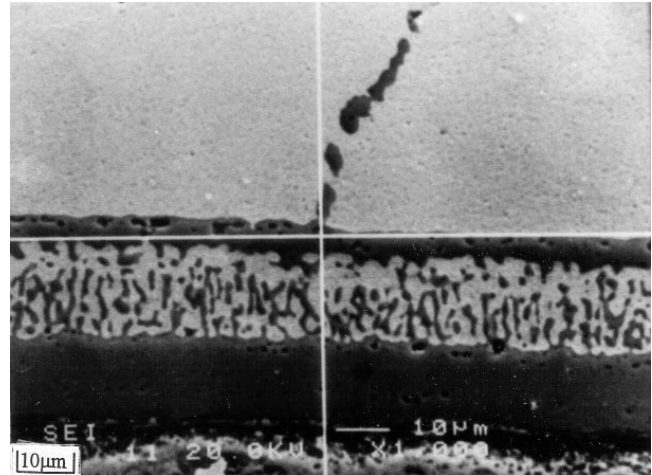

Fig. 7 SEM photograph of the secondary middle layer

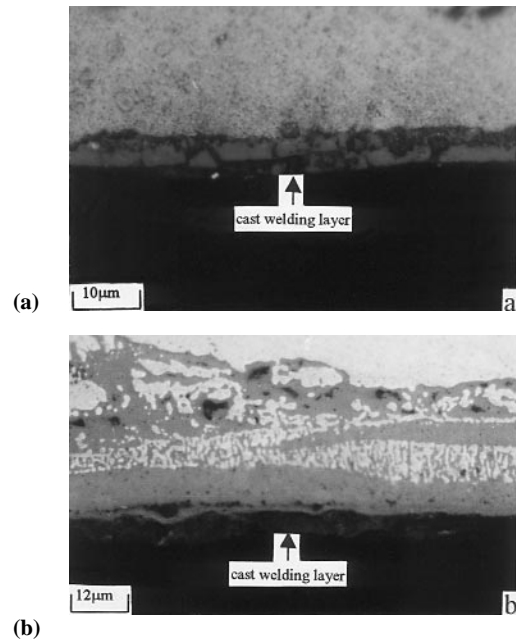

Fig. 8 Push-out fracture morphology of SK3 steel/copper compound casting. (a) Before heated treatment. (b) After marquenching

layer. Another layer close to the copper matrix was the irregular layer. The layer between the prior two layers was the middle layer.

- Through EPMA, it was proved that iron atoms mainly diffused to the copper matrix, and only a relatively few copper atoms diffused to the iron matrix when diffusion proceeded between two matrixes. From x-ray diffraction analysis, it was found that the chemical compounds of the interface were CuFeO_2 and carbon.
- The compound casting had the largest interface shear strength, and the furnace cooling specimen had the lowest interface shear strength.

- The fractured region occurred near the SK3 steel matrix in the cast welding layer.
- The compound casting as a result of water quenching showed a simultaneous improvement in the hardness of the SK3 steel matrix and the interface shear strength.

Acknowledgment

This study was supported by the National Science Council (Taiwan, Republic of China).

References

1. W.F. Schilling and N.J. Grant: *Powder Metall. Int.*, 1973, vol. 5, pp. 117.
2. K.G.K. Warriar and P.K. Rohatgi: *Powder Metall. Int.*, 1986, vol. 29, pp. 65.
3. L.G. Peterson, E.R. Kimml, and R.A. Queeney: *Powder Metall. Int.*, 1973, vol. 5, pp. 65.
4. R.R. Hart, B.C. Wonsiewicz, and B.Y. Chin: *Metall. Trans.*, 1970, vol. 1, pp. 3163-72.
5. A. Chrysanthou and G. Erbaccio: *J. Mater. Sci.*, 1995, vol. 30, pp. 6339.
6. J.M. Howe: *Int. Mater. Rev.*, 1993, vol. 38, pp. 233.
7. D.R. Askeland: *Mater. Sci. Eng.*, 1996, vol. 3, pp. 105.
8. G. Durrant, M. Gallemeault, and B. Cantor: *J. Mater. Sci.*, 1996, vol. 31, pp. 589.
9. F.S. Shieu, R. Raj, and S.L. Sass: *Acta Metall. Mater.*, 1990, vol. 38, pp. 2215.
10. S.K. Choi, M. Chandrasekaran, and M.J. Brabers: *J. Mater. Sci.*, 1990, vol. 25, pp. 1957.
11. Y.C. Lu, S.L. Sass, Q. Bay, D.L. Kohlstedt, and W.W. Gerberich: *Acta Metall. Mater.*, 1995, vol. 43, pp. 31.
12. A.G. Evans, F.W. Zok, and I. Davis: *Comp. Sci. Technol.*, 1991, vol. 42, pp. 3.
13. J.T. Klomp: *Ceramic Microstructures*, p. 307, J.A. Pask and A.G. Evans, Plenum Publishing Co., New York, 1987.
14. D.J. Moore, T.N. Rouns, and K.B. Rundman: *J. Heat Treating*, 1985, vol. 4 (1), pp. 7.
15. M. Qian, S. Harada, L. Yanxiang, and M. Donjun: *Mater. Sci. Eng. A*, 1996, vol. 206, pp. 104.
16. J.W. Hutchinson, M.E. Mear, and J.R. Rice: *J. Appl. Mech.*, 1987, vol. 54, pp. 828.
17. J.R. Rice: *J. Appl. Mech.*, 1988, vol. 55, pp. 98.
18. P.G. Charalambides, H.C. Cao, J. Lund, and A.G. Evans: *Mech. Mater.*, 1990, vol. 8, pp. 269.
19. M.H. Lewis and V.S.R. Murthy: *Compos. Sci. Technol.*, 1991, vol. 42, pp. 211.